



3 YEAR WARRANTY

All new Daystate rifles are guaranteed against faulty parts and labour for a period of 3 years from date of purchase (proof of purchase required). After this period it is recommended that the rifle be returned to Daystate or its authorised agent for a scheduled service and subsequently every 3 years. Servicing is charged at current rates. The warranty applies to the first purchase of a new rifle and is not transferable to subsequent owners.

EXCLUDED FROM WARRANTY

Failure due to misuse or abuse, the fitting of non-standard parts, springs, seals, water-damage to wooden stocks, batteries and fair wear and tear. Daystate Ltd or their approved agent must carry out all maintenance and warranty work. The rifle must be maintained and used as outlined in this Instruction Manual. Should a rifle be returned or collected under warranty, Daystate or its approved agent reserve the right to charge for postage & inspection costs.

While every effort is taken to ensure the accuracy of the information in this instruction manual, Daystate Ltd or their agents cannot be held responsible for errors or omissions. Products are continually updated and specification may change without notice. Visit the online handbook at www.daystate.com/support for the latest information. E&OE.

www.daystate.com

DAYSTATE LTD. UNIT 3, RALEIGH HALL INDUSTRIAL ESTATE, ECCLESHALL, STAFFORDSHIRE ST21 6JL.

© Daystate Ltd. January 2015. E&OE.

Daystate  The Official Handbook



Tenth Edition • Air Ranger • Huntsman Regal • www.daystate.com

Contents

Safety & general information.....	3
Filling your air rifle with compressed air	4
Loading your rifle – single shot	4
Loading the Daystate multi-shot magazine	5
Pellet recommendations.....	6
Recommended maintenance	8
Trigger adjustment	9
Fitting a Rifle Scope	9
Exploded diagrams (all guns)	10
Warranty	12

SAFETY

- Never point your airgun at anyone or anything other than a legitimate target.
- Always check that your airgun is not loaded when you first pick it up.
- Always treat your airgun as if it was loaded, even if you know it's not.
- Never shoot on land where you do not have permission to shoot.
- Always use a safe, large backstop to catch your pellets - and pay due attention to what's behind it, should you miss.
- Never leave your airgun unattended.
- Always store your airgun and pellets separately and securely so that no unauthorised person can use them.
- Know and abide by the laws relating to airguns.

GENERAL INFORMATION

Congratulations on choosing a Daystate air rifle. Your rifle has been hand assembled using the finest materials available, from parts precision made using CNC engineering technology. This rifle is the culmination of Daystate's involvement with pre-charged air rifles and uses knowledge gained from manufacturing this type of air rifle for almost four decades, making your Daystate one of the most accurate and reliable rifles available today. Use this handbook to get the best from you rifle. Further information that includes more detail on the topics covered can be found online at www.daystate.com/support under the online handbook. Daystate also has an active owners club which is free to join and can be found online at <http://v2.daystateowners.com>

FILLING YOUR AIR RIFLE WITH COMPRESSED AIR

Note: Do not use any other gas than clean, dry compressed AIR.

- Remove the dust cap from the rifle's charging connector and attach the female snap-on charging connector onto the inlet valve. Ensure that the outer sleeve is fully forward and that the connection is secure.
- Check that the bleed screw on the charging unit is closed and slowly open the feed valve on the air bottle. Compressed air will now fill the reservoir.
- Fill to the charging pressure marked in the silver disc on the side of the breech block (typically 180 – 230 bar). Close the feed valve. Allow a few minutes for the pressure to 'settle' and then top up if required.
- Sharply open the bleed valve on the charging unit and bleed off the air from the filler hose.
- Remove the snap-on connector and replace the dust cap.

LOADING YOUR RIFLE – SINGLE SHOT

REMEMBER TO KEEP THE MUZZLE OF THE AIR RIFLE POINTING IN A SAFE DIRECTION AT ALL TIMES.

- Apply the safety catch*
- Check that the pellet is not damaged and push the pellet **directly in to the barrel**.
- Push the cocking handle forward and make sure that the handle is down.

THE AIR RIFLE IS NOW LOADED

Disengage the safety catch and the rifle will now fire. The rifle can be 'dry' fired (with air and no pellet in the breech) without any mechanical damage occurring along as there is air in the rifle.

TO PREVENT DAMAGE TO THE RIFLING, ONLY USE SOFT METAL PELLETS

LOADING THE DAYSTATE MULTI-SHOT MAGAZINE.

- Apply the safety catch.
- Lift the cocking handle at the rear of the breech block and pull all the way back until fully cocked. Move bolt forward until a click is felt then remove the magazine from the left side. **Note that the magazine can be factory supplied to be inserted from the right side.**
- The magazine can now be loaded. Load one pellet into the LARGE bottom hole ensuring that the pellet head passes the seating o-ring. Rotate anti clockwise to load each subsequent pellets one click at a time up to a maximum of ten pellets.
- Replace the magazine back into the breech block and return the bolt forward to the closed and locked position.

DIS-ENGAGE THE SAFETY CATCH AND THE RIFLE WILL NOW FIRE.

- To fire the next shot rotate the breech bolt by 45° upwards and pull fully back. The last movement of the bolt is against a spring, which will rotate the magazine. Return the bolt forwards to the locked position to chamber a pellet into the barrel.
- When the last shot is chambered a red dot is displayed on the left side of the magazine. It is possible to remove and 'top up' the magazine should shooting time allow.



TRIGGER ADJUSTMENT

TWO-STAGE TRIGGER - Allen Key Size: 1.5 mm

Note: It is advisable to remove the rifle's action from the stock and the trigger guard to adjust the trigger.

1ST ADJUSTMENT: Adjusts the second stage weight setting. Remove the locking screw. To increase the weight, turn the screw anti-clockwise, and clockwise to lighten the weight. IMPORTANT. Do not adjust this screw too far clockwise as the gun will not cock.

2ND ADJUSTMENT: Enables you to set the angle that the trigger blade sits in the trigger block (factory setting is approximately 90°).

If this is adjusted then the 3rd adjustment will have to be altered.

3RD ADJUSTMENT: This screw will adjust the first stage travel. Turning it anti-clockwise will increase the travel and clockwise will decrease the travel.

NOTE: AFTER ADJUSTING THE TRIGGER IT MAY BE NECESSARY TO ADJUST THE SAFETY CATCH ACTIVATOR SCREW IN OR OUT - TO ENSURE SAFE OPERATION OF THE SAFETY CATCH.

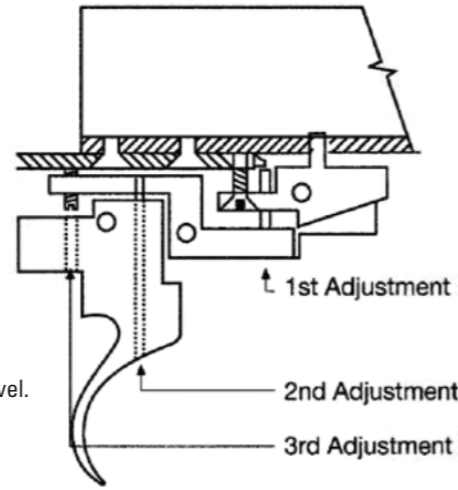

PELLET RECOMMENDATIONS

The Daystate multi-shot magazine has been engineered for round nosed pellets and may misalign or even jam if used with other shapes. In the UK, unlicensed rifles must not be capable of producing power above the legal limit of 12 foot/pounds muzzle energy. The rifle has been set at the factory with sufficient safety margin to ensure compliance with all currently available pellets.

Recommended pellet types - in order of choice:

UP TO 12 FT/LBS (UK unlicensed)
Rangemaster Sovereign

UP TO 30 FT/LBS
Rangemaster Sovereign

UP TO 40 FT/LBS
Rangemaster Monster, Bisley Magnum, H&N Barracuda.

UP TO 60 FT/LBS
Daystate Rangemaster Monster



Fitting a Rifle Scope

Attaching the mounts

Daystate recommend the use of Blueprint Mounts. Loosely fix one mount to the dovetails on the front section of the breech block and the other on the rear*. Place the scope with the scope's saddle to the rear of the magazine as pictured.



Scope shown; MTC Mamba Lite 3-12 x 44
Mounts shown; Blueprint two-piece 25mm medium in black

Aligning the crosshair

You will need either a gun-vice or 'Workmate' as to align the sight the rifle will need to be held firm and level.

- Place the gun vice or workmate on a firm and level surface.
- Clamp the rifle, making sure that you do not damage the stock.
- Place one spirit level across the flat part of the breech block and adjust the rifle until it is level.
- Now look through the sight and without moving the rifle rotate the scope until the vertical cross hair aligns with the plumb line - All screws should now be tightened.

To zero the rifle

- Set up a large paper target, with a safe and suitable backstop at around 12yds
- Mark a simple cross on the target and from about 12 yds (10 metres) . Fire a test shot
- If the pellet is close to the 'mark' then note its position
- If the shot was lower than 5 inches (130 mm) then you will probably run out of adjustment on the elevation turret and it will be necessary to pack up the back of the scope*
- Using the turrets on your scope, adjust until the centre of the crosshair and the pellet hole coincide
- Repeat stages 1-4 at your chosen zeroing distance

*It is quite common when sighting in an airgun to need to tilt the scope forward by shimming the rear mount by up to .3 mm. A good material to use for this purpose is 35mm film negative or lead tape (used to weight golf clubs). Simply cut the shim to the same size as the mount and place it between the scope and the rearmost mount.

RECOMMENDED MAINTENANCE

RECOMMENDED MAINTENANCE

Precharged air rifles contain extremely high pressures and can be dangerous if not serviced correctly. Daystate recommends that all work is carried out by a Daystate factory-trained gunsmith. Correct maintenance will ensure longer trouble free life, therefore Daystate recommend the rifle be returned to the factory or your Daystate approved servicing agent for routine maintenance every three years

BARREL CLEANING

For optimum performance the barrel should be periodically cleaned using felt cleaning pellets lubricated with a barrel cleaning isolation recommended for air rifles or a light grade oil. The frequency depends on the pellets used and the individual barrel, but as general guidance the barrel should be cleaned at least every tin of pellets

AIR RESERVOIR - HUNTSMAN REGAL

The steel under-barrel pressure cylinder on the Huntsman Regal will withstand pressures many times the working pressure of the rifle. To resist corrosion the cylinder is treated with a EC10 coating which will last for many years. Every 10 years the rifle should be returned to the factory or approved agents to be inspected and the air cylinder replaced. Air cylinders are date stamped to assist inspection.

AIR BOTTLE - AIR RANGER

The aluminium under-barrel air bottle fitted to the Air Ranger, will withstand pressures many times the working pressure of the rifle. To resist corrosion the bottle is powder coated with a tough weatherproof finish which will last for many years. Every 10 years the rifle should be returned to the factory or approved agents to be inspected and the bottle replaced and pressure tested to confirm its safety. Air bottles are date stamped to assist inspection.

HAND PUMPS

This type of charger offers an inexpensive and convenient method of charging your rifle. They do not contain the sophisticated water extraction and dirt removal filters found in breathing quality air compressors and their use can shorten the life of sealing valves and o-rings. If you regularly use this type of charger, care should be taken to avoid condensation build-up from inside the pump being transferred to the rifle. The pump should not be used in sandy or dusty conditions. Always refer to the pump manufacturers operating instructions

WALNUT STOCK

Walnut stocks have an oiled finish; the stock should be periodically wiped over with suitable walnut stock oil or boiled lynseed oil.

SOFT TOUCH FINISH

The stock should be periodically wiped over with mild cleaning agent.

ACTION

Daystate recommend that a suitable gun oil is applied to a cloth be used to wipe over the entire outside of the gun, making sure that the entire area is covered with an even amount to protect the metal parts.

LUBRICATION

The bolt shaft should be lubricated with a small amount of light grease. Do not allow any grease to get onto the pellet channel where it could enter the barrel. **DO NOT OIL OR GREASE** any of the internal parts such as the striker or hammer, the inlet valve system or the snap-on connector (filler valve). Doing this could cause problems with consistency & unit sealing.

MORE INFORMATION

More servicing information can be found online at www.daystate.com/support and <http://v2.daystateowners.com>

AirRanger

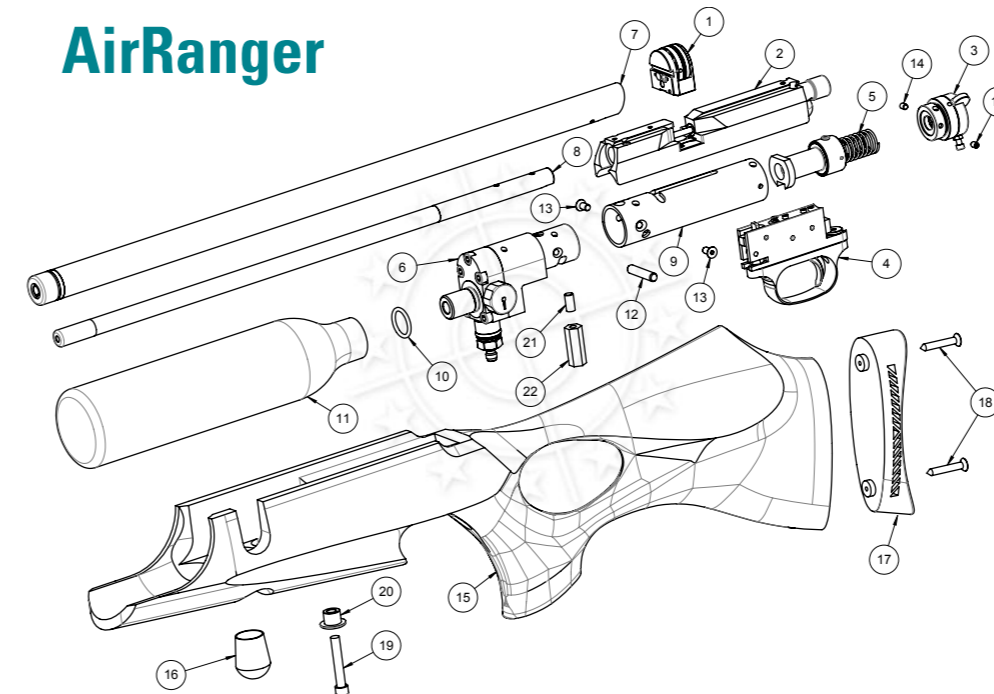

1. Magazine
2. Breech block group assembly
3. Safety catch group assembly
4. Trigger group assembly
5. Hammer group assembly
6. Valve housing group assembly
7. Integral sound moderator group assembly
8. Barrel
9. Striker Housing
10. O-Ring N70 617
11. Bottle 400/500cc
12. Valve body dowel
13. Valve body retaining screw
14. Screw 4BAx1/8"
15. Stock
16. Dust cover
17. Butt pad
18. Butt pad screw
19. Stock bolt
20. Stock bolt washer

Huntsman Regal

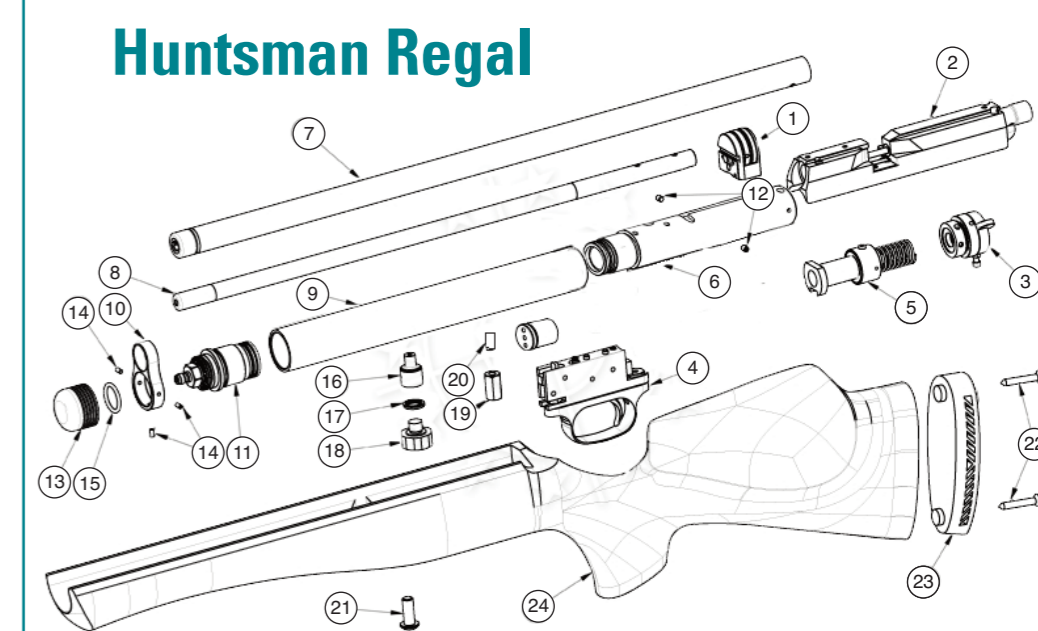

- | | |
|---|--|
| <ol style="list-style-type: none"> 1. Magazine 2. Breech block group assembly 3. Safety catch group assembly 4. Trigger group assy 5. Hammer group assy 6. Valve housing group assy 7. Integral sound moderator group assy 8. Barrel 9. Air Cylinder 10. Barrel support 11. Front Valve Body Assy 12. Screw 4BAx1/8" 13. Dust cover 14. Screw Flat M3x6 | <ol style="list-style-type: none"> 15. O-Ring N70 810 16. Pressure gauge adaptor 17. Dowty Seal 1/8" 18. Pressure sensor 19. Pressure gauge 20. Hexagon retaining nut 21. Stock bolt 22. Butt pad screw 23. Butt pad 24. Stock |
|---|--|